

# FEIDER

## MACHINES

### *INSTRUCTION MANUAL*

#### *PETROL BRUSH CUTTER*

FDBT50-1

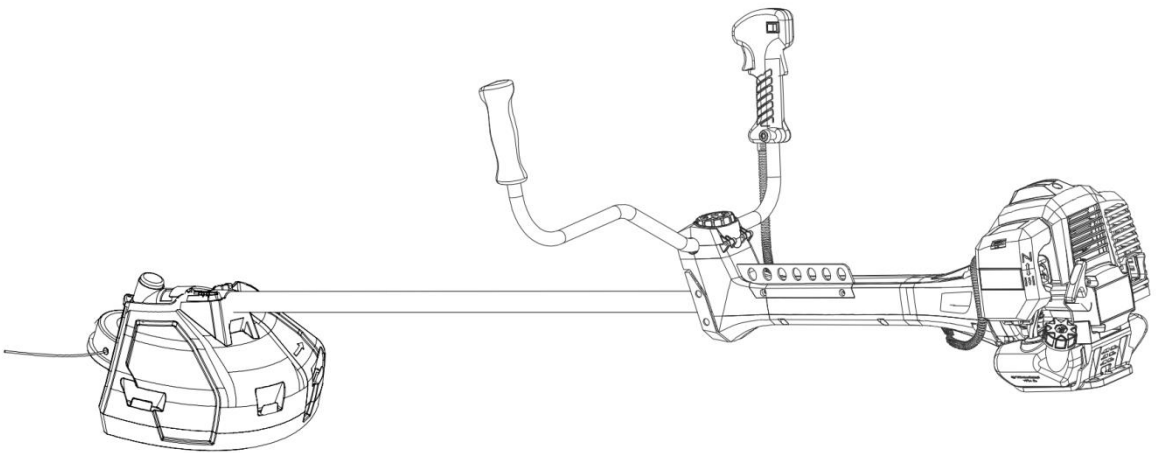

CAUTION: READ THE INSTRUCTION MANUAL BEFORE USE THE TOOL

Feider  
32, rue Aristide Bergès - ZI 31270 Cugnaux - France  
Made in PRC



## 1. Parts location

---

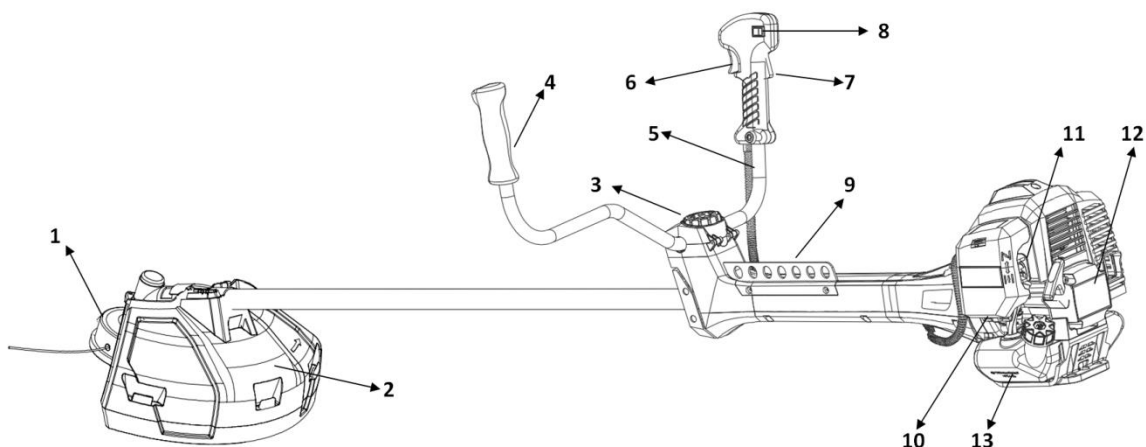

1. Trimmer Head
2. Protection shield
3. Handle bracket
4. Left Handle
5. Right Handle
6. Throttle Trigger
7. Throttle lever

8. Switch
9. Harness Hanger
10. Primer Pump
11. Choke lever
12. Recoil starter
13. Fuel Tank

## 2. Specifications

---

Model no.	FDBT50-1
Engine type	1E43F-B,air-cooled, 2-stroke Engine
displacement	50.8 cm <sup>3</sup>
Maximum engine power	1.7 kW
Max rotational frequency of the spindle	7500/min
Engine idling speed range	3000 min <sup>-1</sup>
Fuel Mixture	Gasoline 40 : Oil 1
Volume of fuel tank	900 cm <sup>3</sup>
Starter	Recoil
Spark plug	BM6A&L8RTF
Weight(without harness and petrol)	8.55 kg
Sound pressure level, L <sub>PA</sub>	Brush cutter: 97,89 dB(A) K=3 dB(A); Grass trimmer: 98,61 dB(A) K=3 dB(A)

Sound power level, Lwa	Brush cutter: 113,16 dB(A) K=3 dB(A); Grass trimmer: 113,99 dB(A) K=3 dB(A)
Guaranteed sound power level, L <sub>WA</sub>	L <sub>WA</sub> : 117 dB(A), k=3 dB(A)
Vibration level	Brush cutter: 6,736 m/s <sup>2</sup> Grass trimmer: 9,185 m/s <sup>2</sup> K=1,5 m/s <sup>2</sup>
Overall size(LxWxH)	1900x650x260 mm
Metal blade	2T: 305mm*1,6 mm 3T, 4T, 8T: 255mm*1,6mm
Cutting line diameter	2.5 mm

### 3. Symbols on the machine

---

For safe operation and maintenance, symbols are carved in relief on the machine. According to these indications, please be careful not to make a mistake.

#### CHOKE OPERATION



Starting mode when the engine is hot (choke off ).

**Position:** AIR CLEANER COVER





















Starting mode when the engine is cold (choke on).

**Position:** AIR CLEANER COVER

### 4. Warning labels on the machine

---

	Warning / Attention		Danger: Risk of fire or explosion
	Read the instruction manual completely and carefully before using the tool.		Top speed of trimmer head is 6600 min <sup>-1</sup>

	Wear head, eye and ear protection.		Top speed of blade is 7100 min <sup>-1</sup>
	Wear protective gloves.		Keep all children, bystanders and helpers 15 meters away from the brush cutter
	Wear safety footwear		The guaranteed noise level
	Danger: Touching the rotating blade is forbidden.		With this symbol the manufacturer confirms that this tool is in accordance with applicable European directives.
	Beware of thrown objects.		<b>Do not use saw blades</b>
	Keep away from fire		<b>BEWARE OF THROWN OBJECTS HIT BY CUTTING ATTACHMENTS. NEVER USE WITHOUT PROPERLY MOUNTED BLADE GUARD. BEWARE OF BLADE THRUST</b>
	Hot surface: Risk of burn.		<b>Keep bystanders away. Never work while people, especially children or pets are nearby.</b>

## 5. For safe operation

Proper safety precautions must be observed. This unit must be handled carefully. DO NOT EXPOSE YOURSELF OR OTHERS TO DANGER.

Follow these general rules. Do not permit others to use this machine unless they are thoroughly responsible and have read, and understand the machine manual and are trained in its operation.

- For machines with a clutch, routines for checking that the cutting attachment stops turning when the engine idles
- Always wear safety goggles for eye protection. Dress properly; do not wear loose clothing or jewellery that could become caught in moving parts of the unit. Safe, sturdy, non-skid footwear should always be worn. Long hair should be tied back. It is recommended that legs and feet be covered to protect from flying debris during operation.
- Inspect the entire machine for loose parts (nuts, bolts, screws, etc.) and any damage. Repair or

replace as necessary before using the machine. DO NOT USE any attachment with this power head other than the ones recommended by our company. Serious injury to the operator or bystanders could result as well as damage to the machine.

- Keep the handles free from oil and fuel.
- Always use proper handles and shoulder strap when cutting.
- Do not smoke while mixing fuel or filling tank.
- Do not mix fuel in an enclosed room or near open flames. Assure adequate ventilation.
- Always mix and store the fuel in a properly marked container that is approved by local codes and ordinances for such usage.
- Never remove the fuel tank cap while the engine is running.
- Never start or run the engine inside a closed room or building. Fumes from the exhaust contain dangerous carbon monoxide.
- Never attempt to make engine adjustments while the unit is running and strapped to the operator. Always make engine adjustments with the unit resting on a flat, clear surface.
- Do not use the unit if it is damaged or poorly adjusted. Never remove the machine's guard. Serious injury to the operator or bystanders could result as well as damage to the machine.
- Inspect the area to be cut and remove all debris that could become entangled in the nylon cutting head. Also remove any objects that the unit may throw during cutting.
- Keep children away. Onlookers should be kept at a safe distance from the work area, at least 15 meters.
- Never leave the machine unattended.
- Do not use this unit for any job other than those for which it is intended as described in this manual.
- Do not overreach. Keep proper footing and balance at all times. Do not run the unit while standing on a ladder or on any other unstable footing location.
- Keep hands and feet clear of the nylon cutting head or blade while unit is in use.
- Do not use this type of machine for sweeping away debris.
- Do not use the unit when you are tired, ill or under the influence of medication, drugs or alcohol.
- Use nylon cutting head which is free of damage. If a stone or any other obstacle is hit, stop the engine and check the nylon cutting head. A broken or unbalanced nylon cutting head must never be used.
- Do not store in a closed area where fuel vapors can reach an open flame from hot water heaters, furnaces, etc. Store the tool in a locked, well-ventilated area only.
- Ensure safe and proper performance of your product. These parts are available from your dealer. The use of any other accessories or attachments may cause a potential hazard or injury to the user, damage to the machine and void this warranty.
- Clean the machine completely, especially, the fuel tank, its surroundings, and the air cleaner.
- When refueling, be sure to stop the engine and confirm that it is cooled down. Never refuel when the engine is running or hot. When gasoline spills, be sure to wipe it up completely dispose of those materials before starting the engine.
- Stay clear of other workers or bystanders by at least 15 meters.
- Whenever approaching an operator of the machine, carefully call his attention and confirm that the operator stop the engine. Be careful not to startle or distract the operator which can cause an unsafe situation.
- Never touch the nylon cutting head or blade whenever the engine is running. If it is necessary to replace the protector or cutting attachment, be sure to stop the engine and confirm that the cutting device has stopped running.
- The engine should be turned off when the machine is moved between work areas
- Be careful not to hit the nylon cutting head against stones, or the ground.
- Unreasonable rough operation will shorten the life of the machine as well as create an unsafe environment for yourself and those around you.

- Pay attention to loosening and overheating of parts. If there is any abnormality of the machine, stop operation immediately and check the machine carefully. If necessary, have the machine serviced by an authorized dealer. Never continue to operate a machine which may be malfunctioning.
- In start-up or during operation of the engine, never touch hot parts such as the muffler, the high voltage wire or the spark plug.
- After the engine has stopped, the muffler is still hot. Never place the machine in any places where there are flammable materials (dry grass, etc.), combustible gasses or combustible liquids.
- Pay special attention to operation in the rain or just after the rain as the ground may be slippery.
- If you slip or fall to the ground or into a hole, release the throttle lever immediately.
- Be careful not to drop the machine or hit it against obstacles.
- Before proceeding to adjust or repair the machine, be sure to stop the engine and detach the spark plug.
- When the machine is placed in storage for a long time, drain fuel from the fuel tank and carburetor, clean the parts, move the machine to a safe place and confirm that the engine is cooled down.
- Make periodic inspections to assure safe and efficient operation. For a thorough inspection of your machine, please contact a dealer.
- Keep the machine away from fire or sparks.
- It is believed that a condition called Raynaud's phenomenon, which affects the fingers of certain individuals, may be brought about by exposure to vibration and cold. Loss of color and numbness in the fingers. The following precautions are strongly recommended because the minimum exposure which might trigger the ailment is unknown.
- Keep your body warm, especially the head, neck, feet, ankles, hands and wrists.
- Maintain good blood circulation by performing vigorous arm exercises during frequent work breaks and also by not smoking.
- Limit the hours of operation. Try to fill each day with jobs where operating the brush cutter or other hand-held power equipment is not required.
- If you experience discomfort, redness and swelling of the fingers followed by whitening and loss of feeling, consult your physician before further exposing yourself to cold and vibration.
- Always wear ear protection, loud noise for long time can make hearing debase even lost hearing.
- Total face and head protection must be wearing to prevent damage from plummet or branch.
- Wear no-slip heavy duty work gloves to improve your grip on the brush cutter handle. Gloves also reduce the transmission of machine vibration to your hands.
- **WARNING:** The cutter area is still dangerous while the machine is coasting to a stop.
- When transport, this unit must be handled carefully. Do not expose yourself or others to danger.
- Envelop the blade before storage. Keep children away from it.
- Never remove the machine's guard.
- Never place the machine in any places where there are flammable materials (dry grass, etc.), combustible gasses or combustible liquids.
- When the machine is placed in storage for a long time, drain fuel from the fuel tank and carburetor, clean the parts, move the machine to a safe place and confirm that the engine is cooled down.
- **Warning – the tool emits dangerous exhaust gases. Do inhale them and stay away from these gases.**
- National regulation can restrict the use of the machine.
- Never modify a trimmer or cutter in any way.
- Improper use of the machine can cause **SERIOUS OR FATAL PERSONAL INJURY**.
- The engine exhaust form this product contains chemicals to cause cancer, birth defects, of other reproductive harm.
- Checking regularly that the cutting attachment stops turning when the engine idles.
- Use recommended cutting attachments and appropriate. Contact your dealer or our service agent to know which cutting attachment can be used with this tool. There are possible safety consequences from using other cutting attachments, e.g. metal multi-piece pivoting chains and flail blades.

- Check each time before and after use, after a fall or other impacts to identify any significant damage.
- Do not use the tool in case of damage. Bring it to a qualified service agent for inspection and reparation.
- Risks and problems may occur during the operation, follow the instructions in this manual to reduce these risks.
- If the machine or cutting attachment needs to be unlocked, stop using the tool, remove the spark plug. Wear safety protection to unlock the tool.
- Do not work prolonged with the tool, take regular breaks during the operation.
- Always keep a correct posture, do not use the tool in a position that could create accidents.
- Secure the machine during transport to prevent loss of fuel, damage or injury. Always put the protection devices on the blades. Always transport the tool upright.
- Put the protection on the blade when storing the tool.
- Hazards which could be encountered while using the machine (bump a foreign object, blockage of the cutting attachment, etc.). In order to avoid hazards, inspect thoroughly the working area; remove all hazardous material and object which may be present.

#### Kickback and Related Warnings

- Kickback is a sudden reaction to a pinched or snagged rotating wheel, backing pad, brush or any other accessory. Pinching or snagging causes rapid stalling of the rotating accessory which in turn causes the uncontrolled power tool to be forced in the direction opposite of the accessory's rotation at the point of the binding.
- For example, if an abrasive wheel is snagged or pinched by the workpiece, the edge of the wheel that is entering into the pinch point can dig into the surface of the material causing the wheel to climb out or kick out. The wheel may either jump toward or away from the operator, depending on direction of the wheel's movement at the point of pinching. Abrasive wheels may also break under these conditions.
- Kickback is the result of power tool misuse and/or incorrect operating procedures or conditions and can be avoided by taking proper precautions as given below:
  - o Never place your hand near the rotating accessory. Accessory may kickback over your hand.
  - o Do not position your body in the area where power tool will move if kickback occurs. Kickback will propel the tool in direction opposite to the wheel's movement at the point of snagging.
  - o Use special care when working corners, sharp edges etc. Avoid bouncing and snagging the accessory. Corners, sharp edges or bouncing have a tendency to snag the rotating accessory and cause loss of control or kickback.

#### Residual risks

Even if you use this tool correctly, there are always residual risks. The following hazards may arise in connection with the structure and manufacture of this power tool:

- Hearing impairment if no suitable hearing protection is worn.
- Cuts if no suitable protective clothing is worn.
- Health damage resulting from vibration in the hands and arms if the device is used for a long period of time or is not handled and maintained properly.
- Inhalation of particles
- Inhalation of exhaust gases
- Skin contact with oil / gasoline
- Inhalation of gasoline / oil vapors
- Contact with projected objects
- Burns when touching with hot surfaces
- Prolonged use of this product exposes the operator to vibration and can produce so-called "white finger" disease. To reduce the risk, wear gloves and keep your hands warm.
- If any of the symptoms of "white finger syndrome" occur, seek immediate medical attention. Symptoms of the "white finger" include numbness, loss of sensitivity, tingling, pain, loss of strength,

color changes or skin condition. These symptoms usually appear on the fingers, hands or wrists. Risk increases at low temperatures.

#### Intended use

This machine can be used with the cutting wire as a trimmer for cutting grass and weeds of small thickness and in small quantity and with the cutting blade as a brush cutter for cutting denser vegetation. This machine must not be used for cutting or other cutting operations where the cutting tool must be lifted above the ground. This machine is only authorized for private use. Any other use or modification of this machine is prohibited and involves high risks.

## 5. Set up

**Warning – Be careful of sharp edges when assembly. Wear protective gloves.**

01

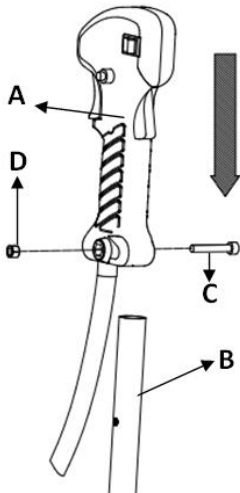

02

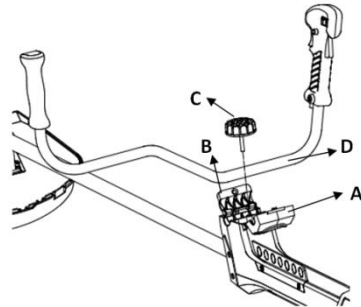

03

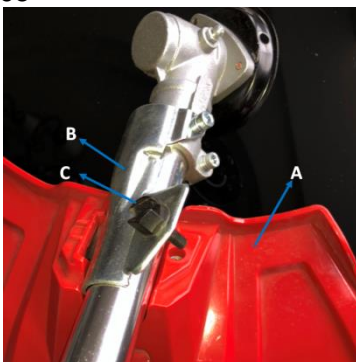

04

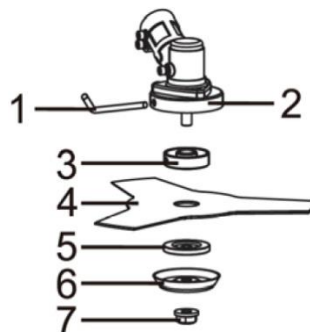



### ■ INSTALLING RIGHT AND LEFT HANDLE (01)

1. Loosen the bolt C and nut D from the right handle.
2. Insert the handle pipe B into right handle A, lock the bolt C and nut A securely.

### ■ INSTALLING HANDLE (02)

1. Press to open the handle bracket cap A and loosen the fixing knob C on the handle bracket B.
2. Put the handle assembly D into the bracket B and put the cap A over it. Tighten the cap A securely.

### ■ INSTALLING PROTECTION SHIELD (03)

1. Put the left side of plate B inside the protection shield A.
2. Attach the plate B to protection shield A with bolt C. Make sure the bolt is tightened securely.

### ■ INSTALLING CUTTING BLADE (04)

1. Put the angled bar (1) into the side holes of the gear case (2) and the plate (3) so as to fasten the axle.
2. Mount the blade (4) and the washer (5) onto the axle.
3. Mount the washer (6) and the nut (7). Fasten tightly anti-clockwise.



For different kind of blade, you can install in the same way.

## 6. Set up

---

05

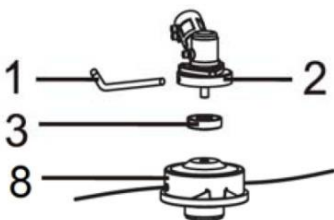

06

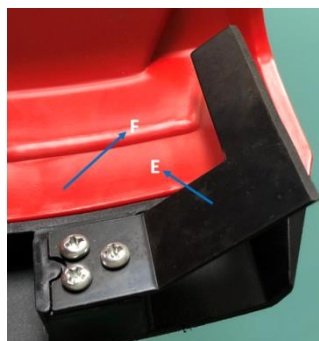

### ■ INSTALLING CUTTING HEAD (05)

1. Put the angled bar (1) into the side holes of the gear case (2) and the plate (3) so as to fasten the axle.

2. Mount the trimmer head (8) on the axle. Fasten tightly anti-clockwise.

 **NOTE (06)**

Before using the trimmer head, mount the trimmer knife (E) to protection shield (F) with 3 screws. When the machine is running, tap the trimmer head on the ground, and trimmer line will come out automatically. The trimmer knife will cut and keep the trimmer line in the correct length.

■ **HARNESS**

 **WARNING**

- **ALWAYS WEAR THE PROVIDED HARNESS WHEN USING THE MACHINE!**
- Always make sure the machine is hooked securely to the harness. If you don't, you will be unable to control the machine safely. This can result in injury to yourself or others.
- Never use a harness with a defective quick release or any other damage.

**HOW TO WEAR**

1. Wear the provided harness without twisted bands, with the hanger (1) on your right side.

■ **BALANCE THE UNIT**

1. Hook your machine to the hanger.
2. Adjust the bands of the harness to have the blade parallel to the ground when standing in your normal working position to provide you most effectiveness and comfort on operating the machine.
3. In order to prevent the hanger position to change during operation, turn up the extra part of the band from the buckle.
4. When correctly adjusted, check the correct working of the harnesses' QUICK RELEASE.

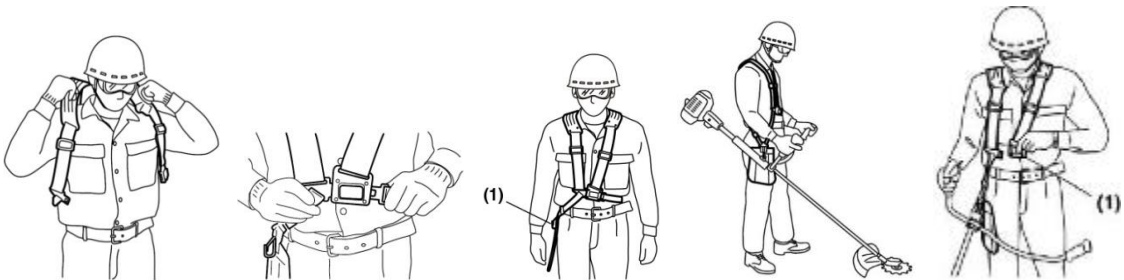

**7. Fuel**

---

**Mixing ratios:**

When using commercially available 2-cycle oil (FB grade): **40 : 1**



## **WARNING**

- Gasoline is very flammable. Avoid smoking or bringing any flame or sparks near fuel.
- Wipe up all spills before starting the engine.
- Make sure to stop the engine and allow it cool before refueling the unit.
- Keep open flames away from the area where fuel is handled or stored.

## **IMPORTANT**

- Never use oil for 4 cycle engine use or water cooled 2-cycle engine.
- Never use "FUEL WITH NO OIL (RAW GASOLINE)".
- Never use fuel laced with water.
- Mixed fuels which have been left unused for a period of one month or more may clog the carburetor or result in the engine failing to operate properly. Put remained fuel into an air-tight container and keep it in the dark and cool room.
- Please ask for "mixed gasoline for air-cooled 2-cycle engines" at your nearest gas station, or use fuel made by putting unleaded gasoline for automobiles and air-cooled 2-cycle engine oil into a mixing container in accordance with the following ratios and then shaking to mix well.

### ■ **HOW TO MIX FUEL**

1. Measure out the quantities of petrol and oil to be mixed.
2. Put some of the petrol into the clean, approved fuel container supplied.
3. Pour in the oil and agitate well.
4. Be careful that, if the agitation is insufficient, there is an increased danger of early piston seizing due to abnormally lean mixture.

### ■ **FUELING THE UNIT**

1. Untwist and remove the fuel cap. Rest the cap on a dustless place.
2. Pour fuel into the fuel tank to 80% of the full capacity.
3. Fasten the fuel cap securely and wipe up any fuel spillage around the unit.

#### **WARNING**

1. Select bare ground for fueling.
2. Move at least 10ft (3m) away from the fueling point before starting the engine.
3. Stop the engine before refueling the unit. At that time, be sure to sufficiently agitate the mixed petrol in the container.
4. In the case of storing the product for a long period of time, clean the fuel tank after rendering it empty. Next, activate the engine and empty the carburetor of the composite fuel.

## **8. Operation**

---

### ■ **STARTING ENGINE**

#### **WARNING**

The cutting head will start rotating upon the engine starts.

1. Feed fuel into the fuel tank and tighten the cap securely.
2. Rest the unit on a flat, firm place. Keep the cutting head off the ground and clear of surrounding objects as it will start rotating upon starting of the engine.
3. Push the primer pump several times until overflowed fuel flows out in the return tube.



3. Move the choke lever to the closed position.



Closed position



Open position

4. Set the ignition switch to the “start” position. While pulling the throttle lever, push the throttle set button, and release the throttle, then the throttle lever is into the “Start position.”



Stop position

Start position



5. While holding the unit firmly, pull out the starter rope quickly until engine fires.



### **!** IMPORTANT

- Avoid pulling the rope to its end or returning it by releasing the knob. Such actions can cause starter failures.

6. Move the choke lever to the open position. And pull out the starter rope quickly to restart engine.



## **8. Operation**

---

7. Allow the engine to warm up for several minutes before starting operation.

### **📖** NOTE

1. When restarting the engine immediately after stopping it, leave the choke open and push the primer pump several times.
2. Overchoking can make the engine hard to start due to excess fuel. When the engine failed to start after several attempts, open the choke and repeat pulling the rope, or remove the spark plug and dry it.

### **■ STOPPING ENGINE**

1. Release the throttle lever and run the engine for a half minute.
2. Shift the ignition switch to the STOP position.

### **📖** NOTE

- Except for an emergency, avoid stopping the engine while pulling the throttle lever.

### **■ ADJUSTING IDLING SPEED (OP5)**

1. When the engine tends stop frequently at idling mode, turn the adjusting screw clockwise.
2. When the cutting head keeps rotating after releasing the trigger, turn the adjusting screw

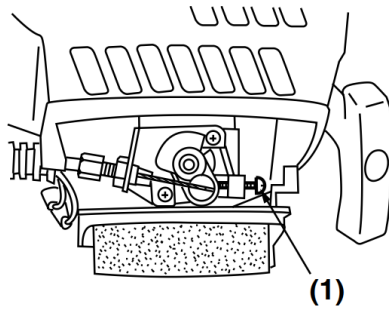

### (1) Idle speed adjuster

#### NOTE

- Warm up the engine before adjusting the idling speed.

#### ■ TRIMMER HEAD USAGE

#### WARNING

1. Always wear eye protection such as safety goggles. Never lean over the rotating cutting head. Rocks or other debris could be thrown into eyes and face and cause serious personal injury.
2. Keep the debris guard attached in place at all times when the unit is operated.

#### TRIMMING GRASS AND WEEDS

- Always remember that the TIP of the line does cutting. You will achieve better results by not crowding the line into the cutting area. Allow the unit to trim at its own pace.

1. Hold the unit so the head is off the ground and is tilted about 20 degrees toward the sweep direction.

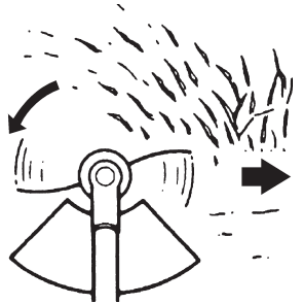

2. You can avoid thrown debris by sweeping from your right to the left.
3. Use a slow, deliberate action to cut heavy growth. The rate of cutting motion will depend on the material being cut. Heavy growth will require slower action than will light growth.
4. Never swing the unit as hard as you are in danger of losing your balance or control of the unit.
5. Try to control the cutting motion with the hip rather than placing the full workload on the arm and hands.
6. Take precautions to avoid wire, grass and dead, dry, long-stem weeds from wrapping around the head shaft. Such materials can stall the head and cause the clutch to slip, resulting in damage to the clutch system.

## 8. Operation

---

### ADJUSTING THE LINE LENGTH

- Your brushcutter is equipped with a semi- auto type nylon line head that allows the operator to advance the line without stopping the engine. When the line becomes short, lightly tap the head on the ground while running the engine at full throttle.
- Each time the head is bumped, the line advance about 1 inch (25.4 mm). For better effect, tap the head on bear ground or hard soil. Avoid bumping in thick, tall grass as the engine may stall by overload.

### ■ METAL BLADE USAGE

#### NOTE

Choose a suitable recommended cutting attachment according to the object to be cut.

#### WARNING

- When sharpening, removing, or reattaching the blade, be sure to wear thick, sturdy gloves.

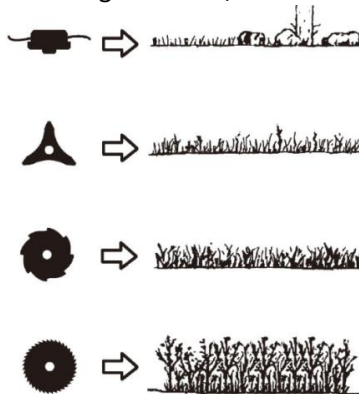

1. Check the bolt to fasten the blade and be sure the bolt has no fault, and no abrasion.
2. Be sure that the blade and the holder have been fastened according to instruction and the blade turns smoothly without abnormal noise.



#### WARNING

- The rotating parts fastened incorrectly may cause serious accident to the operator.
  - Make sure that the blade is not bent, warped, cracked, broken or damaged.
  - If you find any error to the blade, discard it and change new one.
- 
- By using the harness, hang the unit on your right side. Adjust the harness length so that the cutting head may become parallel to the ground.

#### WARNING

- Make sure to use harness and cutting attachment guard. If not, it is very dangerous since you slip or lose your balance.



#### ■ CUTTING METHOD

- Use the front left side cutting.
- Guide the blade from your right to left with it tilted slightly to your left.

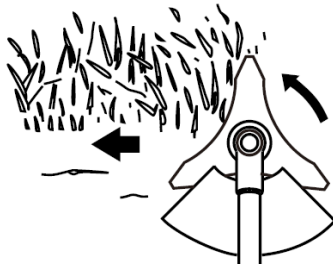

- When mowing a wide area, start working from your left end to avoid interference of cut grass.
- The blade may be seized by weeds if the engine speed is too low, or the blade cuts too deep into weeds. Adjust the engine speed and cutting depth according to the condition of object.

#### **⚠** WARNING

- If the grass or other object gets caught in the blade, or if the unit starts to shake or vibrate, turn off the engine and check the whole unit. Change the blade if it has been damaged.

## 9. Maintenance

---

Always provide maintenance of the tool before storage. Maintenance must be regularly provided. Lack of maintenance or improper maintenance will reduce the lifetime of the tool, and can provide bad operation result and potential accidents and injuries.

After each operation, inspect the tool; check for loose fasteners, fuel leaks and damaged parts, such as cracks in the cutting attachment. In case of any default, do not use the tool and bring to a qualified service agent for inspection and reparation.

**Always clean and grind the blade, check whether the blade is firmly installed before use, and check whether the blade is damaged if it encounters obstacles. If it is not used for a long time, clean the blade surface and apply lubricant to avoid rust.**

#### **⚠** WARNING

- Always be sure to stop the engine before inspecting the brush cutter for problems or performing maintenance.
- Never alter the brush cutter or take the engine apart.



	System/components	Procedure	Before use	Every 25 hours after	Every 50 hours after	Every 100 hours after	Note
ENGINE	fuel leaks, fuel spillage	wipe out	✓				
	fuel tank, air filter, fuel filter	inspect/clean	✓	✓			replace, if necessary
	idle speed adjuster	see adjusting idling speed	✓				replace carburetor if necessary
	spark plug	clean and readjust plug gap			✓		GAP: .025 in (0.6 ~ 0.7 mm) replace, if necessary
	intake air cooling vent	clean		✓			
SHAFT	throttle trigger, stop switch	check operation	✓				
	cutting parts	replace if something's wrong	✓				
	angle transmission	grease		✓			
	screws/nuts/bolts	tighten/replace	✓			✓	except adjusting screws
	cutting attachment guard	make sure to attach	✓				

### ■ REFILLING TRIMMING LINE

1. When the trimmer line is about to run out, you need to reload a new one. For replacement line, use a diameter of 2.4mm (.095in). The spool is capable for a line up to 4m. Avoid using a larger line as it may cut down the trimming performance.

2. Line up the arrow marks on knob and body of the head. Pull out the trimmer line from one side.

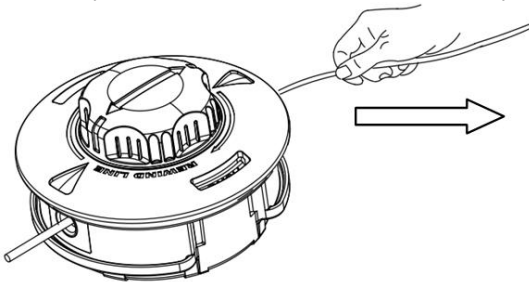

3. Insert new trimmer line through one of the eyelets to the other side.

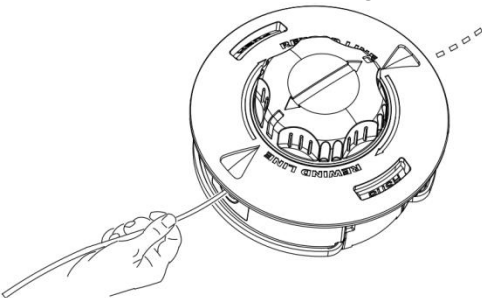

4. Extend both ends of the line until their length matches.

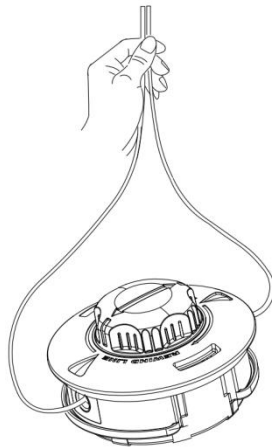

## 9. Maintenance

---

5. Wind up the line in the correct direction as indicated on the spool.

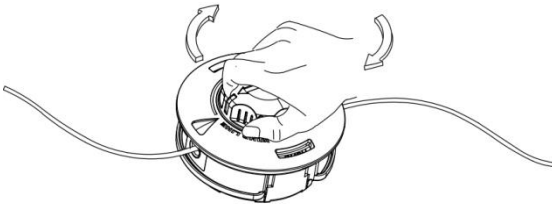

6. Leave the trimmer line around 160mm. Assembly is finished.

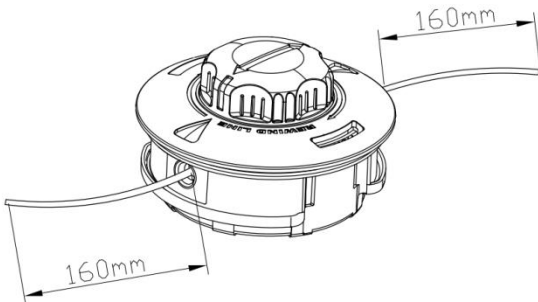

### ■ AIR FILTER

- The air filter, if clogged, will reduce the engine performance. Monthly check and clean the filter element in warm, soapy water as required. Dry completely before installing. If the element is broken or shrunk, replace with a new one.



### ■ FUEL FILTER

- When the engine runs short of fuel supply, check the fuel cap and the fuel filter for blockage.

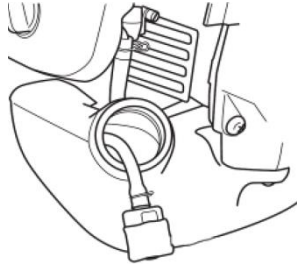

### ■ SPARK PLUG

- Starting failure and misfiring are often caused by a fouled spark plug. Clean the spark plug and check that the plug gap is in the correct range. For a replacement plug, use the correct type
- Periodically clean the spark plug and check that the spark gap is in the correct range.

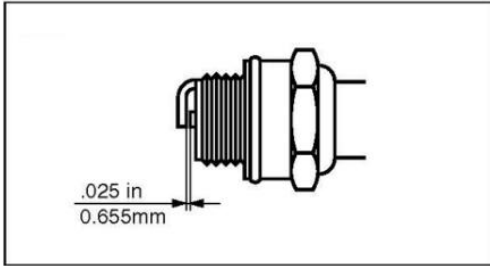

### ⚠ IMPORTANT

- Note that using any spark plugs other than those designated may result in the engine failing to operate properly or in the engine becoming overheated and damaged.
- To install the spark plug, first turn the plug until it is finger tight, then tighten it a quarter turn more with a socket wrench.

TIGHTENING TORQUE: 9.8~11.8 N.m

### ■ MUFFLER

### ⚠ WARNING

- **Inspect periodically, the muffler for loose fasteners, any damage or corrosion. If any sign of exhaust leakage is found, do not use the brush cutter and have it repaired immediately.**
- **Note that failing to do so may result in the engine catching on fire.**

## 10.Storage

---

Aged fuel is one of major causes of engine starting failure. Before storing the unit, empty the fuel tank and run the engine until it uses all the fuel left in the fuel line and the carburetor. Store the unit indoor taking necessary measures for rust prevention.

## 11.Transportation

---

1. When hand-carrying the product, cover over the cutting part if necessary, lift up the product and carry it paying attention to the blade.
2. Never transport the product over rough roads over long distances by vehicle without removing all fuel from the fuel tank. If doing so, fuel might leak from the tank during transport.

## 12. Troubleshooting guide

---

### Starting failure

---

CHECK	PROBABLE CAUSES	ACTION
Fuel tank	→ incorrect fuel	→ drain it and with correct fuel
Fuel filter	→ fuel filter is clogged	→ clean
Carburetor adjustment screw	→ out of normal range	→ adjust to normal range
Sparking (no spark)	→ spark plug is fouled/wet	→ clean/dry
Plug gap	→ plug gap is incorrect	→ correct (GAP: 0.6~0.7mm)
Spark plug	→ disconnected	→ retighten

---

### Engine starts but does not keep running/Hard re-starting.

---

CHECK	PROBABLE CAUSES	ACTION
Fuel tank	→ incorrect fuel or staled fuel	→ drain it and with correct fuel
Carburetor adjustment screw	→ out of normal range	→ adjust to normal range
Muffler, cylinder (exhaust port)	→ carbon is built-up	→ wipe away
Air cleaner	→ clogged with dust	→ wash
Cylinder fin, fan cover	→ clogged with dust	→ clean

---

When your unit seems to need further service, please consult our service agent.

### 13. DECLARATION OF CONFORMITY

#### GB / DECLARATION OF CONFORMITY



**Feider**

ZI, 32, rue Aristide Bergès – 31270 Cugnaux - France  
Tel: +33 (0)5.34.502.502 Fax: +33 (0)5.34.502.503

Declares that the machines:  
**GASOLINE BRUSH CUTTER**  
**Model: FDBT50 -1**

**Serial No.: 20210852958-20210853157**

The people name holding the technical file: M. Olivier Patriarca

Have been designed in compliance with the following standards:

EN ISO 11806-1:2011

EN ISO 14982:2009

And in accordance with the following directives:

Directive Machine 2006/42/EC

Directive EMC 2014/30/EU

Emission directive (EU) 2016/1628 & 2018/989/EU

Noise Directive 2000/14/EC Annex V & Directive 2005/88/EC

Rohs Directive (EU)2015/863 amending 2011/65/EU

Sound power level, L <sub>WA</sub>	Brush cutter: 113,16 dB(A) K=3 dB(A); Grass trimmer: 113,99 dB(A) K=3 dB(A)
Guaranteed sound power level, L <sub>WA</sub>	L <sub>WA</sub> : 117 dB(A)

Philippe MARIE / PDG  
Cugnaux, 18-05-2021

# 14. WARRANTY



## WARRANTY

The manufacturer guarantees the product against defects in material and workmanship for a period of 2 years from the date of the original purchase. The warranty only applies if the product is for household use. The warranty does not cover breakdowns due to normal wear and tear.

The manufacturer agrees to replace parts identified as defective by the designated distributor. The manufacturer does not accept responsibility for the replacement of the machine, in whole or in part, and/or ensuing damage.

### The warranty does not cover breakdowns due to:

- insufficient maintenance.
- abnormal assembly, adjustment or operations of the product.
- parts subject to normal wear and tear.

### The warranty does not extend to:

- shipping and packaging costs.
- using the tool for a purpose other than that for which it was designed.
- the use and maintenance of the machine done in a manner not described in the user manual.

Due to our policy of continuous product improvement, we reserve the right to alter or change specifications without notice. Consequently, the product may be different from the information contained therein, but a modification will be undertaken without notice if it is recognized as an improvement of the preceding characteristic.

### READ THE MANUAL CAREFULLY BEFORE USING THE MACHINE.

When ordering spare parts, please indicate the part number or code, you can find this in the spare parts list in this manual. Keep the purchase receipt; without it, the warranty is invalid. To help you with your product, we invite you to contact us by phone or via our website:

- **+33 (0)9.70.75.30.30**
- **<https://services.swap-europe.com/contact>**

You must create a "ticket" via the web platform.

- Register or create your account.
- Indicate the reference of the tool.
- Choose the subject of your request.
- Describe your problem.
- Attach these files: invoice or sales receipt, photo of the identification plate (serial number), photo of the part you need (for example: pins on the transformer plug which are broken).



# 15. PRODUCT FAILURE

## WHAT TO DO IF MY MACHINE BREAKS DOWN?

### If you bought your product in a store:

- a) Empty the fuel tank.
- b) Make sure that your machine is complete with all accessories supplied, and clean! If this is not the case, the repairer will refuse the machine.

Go to the store with the complete machine and with the receipt or invoice.

### If you bought your product on a website:

- a) Empty the fuel tank.
- b) Make sure that your machine is complete with all accessories supplied, and clean! If this is not the case, the repairer will refuse the machine.
- c) Create a SWAP-Europe service ticket on the site: <https://services.swap-europe.com> When making the request on SWAP-Europe, you must attach the invoice and the photo of the nameplate (serial number).
- d) Contact the repair station to make sure it is available before dropping off the machine.

Go to the repair station with the complete machine packed, accompanied by the purchase invoice and the station support sheet downloadable after the service request is completed on the SWAP-Europe site

For machines with engine failure from manufacturers BRIGGS & STRATTON, HONDA and RATO, please refer to the following instructions.

Repairs will be done by approved engine manufacturers of these manufacturers, see their site:

- <http://www.briggsandstratton.com/eu/fr>
- <http://www.honda-engines-eu.com/fr/service-network-page;jsessionid=5EE8456CF39CD572AA2AEEDFD290CDAE>
- <https://www.rato-europe.com/it/service-network>

**Please keep your original packaging to allow for after-sales service returns or pack your machine with a similar cardboard box of the same dimensions.**

**For any question concerning our after-sales service you can make a request on our website <https://services.swap-europe.com>**

**Our hotline remains available at +33 (9) 70 75 30 30.**



# 16. WARRANTY EXCLUSIONS

## THE WARRANTY DOES NOT COVER:

- Start-up and setting up of the product.
- Damage resulting from normal wear and tear of the product.
- Damage resulting from improper use of the product.
- Damage resulting from assembly or start-up not in accordance with the user manual.
- Breakdowns related to carburetion beyond 90 days and fouling of carburetors.
- Periodic and standard maintenance events.
- Actions of modification and dismantling that directly void the warranty.
- Products whose original authentication marking (brand, serial number) has been degraded, altered or withdrawn.
- Replacement of consumables.
- The use of non-original parts.
- Breakage of parts following impacts or projections.
- Accessories breakdowns.
- Defects and their consequences linked to any external cause.
- Loss of components and loss due to insufficient screwing.
- Cutting components and any damage related to the loosening of parts.
- Overload or overheating.
- Poor power supply quality: faulty voltage, voltage error, etc.
- Damages resulting from the deprivation of enjoyment of the product during the time necessary for repairs and more generally the costs related to the immobilization of the product.
- The costs of a second opinion established by a third party following an estimate by a SWAP-Europe repair station
- The use of a product which would show a defect or a breakage which was not the subject of an immediate report and/or repair with the services of SWAP-Europe.
- Deterioration linked to transport and storage\*.
- Launchers beyond 90 days.
- Oil, petrol, grease.
- Damages related to the use of non-compliant fuels or lubricants.

\* In accordance with transport legislation, damage related to transport must be declared to carriers within 48 hours maximum after observation by registered letter with acknowledgement of receipt.

This document is a supplement to your notice, a non-exhaustive list.

**Attention:** all orders must be checked in the presence of the delivery person. In case of refusal by the delivery person, it you must simply refuse the delivery and notify your refusal.

**Reminder:** the reserves do not exclude the notification by registered letter with acknowledgement within 72 hours.

### Information:

Thermal devices must be wintered each season (service available on the SWAP-Europe site). Batteries must be charged before being stored.